

Burger King Vertical Contact Toaster

International Owner's Manual

Manufacturing Number:
9210131



Table of Contents

Overview	2
Before Use	2
In Case of Damage	2
Website	2
Service/Technical Assistance	2
In Case of Damage	2
Equipment Information to Save	2
Authorized Service Agency	2
Safety Information	3
Installation	3
Maintenance	3
Service	3
Specifications	4
Unpacking	5
Operating Instructions	6
Startup	6
System Cooldown	6
Toasting	6
Adjusting Toasting Settings	6
Adjusting Bun Compression	6
Status Menu	7
Error Log	7
Program Menu	7
Reset Menu	7
Daily Maintenance	8
Cleaning Accessories & Toaster	8
Cleaning the Release Sheet	8
Cleaning the Conveyor Belts	8
Quarterly Maintenance	9
Clean Cooling Fan	9
Checking Conveyor Chains	9
Error Messages	10
Wiring Diagram	11
Notes	12
Limited Warranty	13

Overview

2 This unit is intended to be used
2 for commercial applications, for
2 example: in kitchens of restaurants,
2 canteens, hospitals and in
2 commercial enterprises such as
2 bakeries, butcheries, etc., but not for
2 continuous mass production of food.

Before Use

3 This manual contains safety,
3 installation, and operating
4 procedures for the unit. Read and
5 understand it completely before
6 installing or operating the unit. Keep
6 this document for reference. If the
6 unit changes ownership, this manual
6 must accompany it.

In Case of Damage

7 If the unit arrives damaged, file a
7 claim with the carrier immediately.
8 Save all packing materials when
8 filing a claim. Freight damage
8 claims are the responsibility of the
8 purchaser and are not covered under
9 warranty.

Website

11 www.antunes.com

Service/Technical Assistance

In Case of Damage

If any parts are missing or damaged, problems with the installation or operation of this product contact Antunes Customer Service immediately at +1-877-392-7856 (toll free).

Fill in the information in the next section and have it ready when calling for assistance. The serial number is on the specification sticker located on the system.

Equipment Information to Save

Purchased from:

Date of purchase:

Model number:

Serial number:

Manufacturing number:

Authorized Service Agency

Name:

Phone No:

Address:

Safety Information

Installation

- Read and understand all instructions before installing or using the unit.
- Install this unit to comply with the basic plumbing code of the Building Officials and Code Administrators, Inc. (BOCA) and the Food Service Sanitation Manual of the Food and Drug Administration (FDA).
- Install and locate the equipment only for its intended use as described in this manual.



WARNING

ELECTRICAL SHOCK HAZARD.
Failure to follow the instructions in this manual could result in serious injury or death.

Do not modify the power supply cord plug. If it does not fit the outlet, have a proper outlet installed by a qualified electrician.

Electrical ground is required on this appliance.

Check with a qualified electrician if you are unsure if the appliance is properly grounded.

Do NOT use an extension cord with this product.

The unit should be grounded according to local electrical codes to prevent the possibility of electrical shock. It requires a grounded receptacle with separate electrical lines, protected by fuses or circuit breaker of the proper rating.

NEVER unplug the power cord while the unit is running. Use the proper shutdown procedure before unplugging the power cord.

Operation

- The unit is furnished with a properly grounded cord connector. Do not attempt to defeat the grounded connector.
- Do not operate the unit if it has been damaged or dropped, if it has a damaged cord or plug, or if it is not working properly.
- Do not block or cover any openings on the equipment.
- Do not immerse the cord, unit, or plug in water.
- Keep the cord away from heated surfaces.
- Do not allow the cord to hang over the edge of a table or counter.
- This appliance is not to be used by persons (including children) with reduced physical, sensory or mental capabilities, or lack of experience and knowledge unless they have been given supervision or instruction.
- Children being supervised are not to play with the appliance.
- Bread may burn. Therefore toasters must not be used near or below curtains or other combustible walls and materials. Failure to maintain safe operating distances may cause discoloration or combustion.

Maintenance

- Do not use abrasive materials; they can damage the unit's stainless steel finish.
- Do not use corrosive chemicals in this equipment.
- Chlorides or phosphates in cleaning agents (e.g., bleach, sanitizers, degreasers, and detergents) can permanently damage stainless steel equipment. The damage is usually in the form of discoloration, dulling of the metal surface finish, pits, voids, holes, or cracks. This damage is permanent and is not covered by warranty.
- Always use a soft, damp cloth for cleaning. Rinse with clear water and wipe dry. When required, always rub in the direction of metal polish lines.
- Routine cleaning should be performed daily with soap and water.
- Rub off finger marks and smears using soap and water.
- Do not clean the unit with a water jet or steam cleaner.

Service

- Inspection, testing, and repair of electrical equipment must be performed only by qualified service personnel.
- To avoid possible personal injury and/or damage to the unit, all inspections, tests, and repair of electrical equipment should be performed by qualified personnel ONLY. Contact Antunes Technical Service for adjustment or repair.
- Turn the power off, unplug the power cord, and allow unit to cool to room temperature before performing any service or maintenance.
- If the supply cord is damaged, it must be replaced by the manufacturer, its service agent, or a similarly qualified person in order to avoid an electrical hazard.
- Cleaning and user maintenance shall not be made by children without supervision.

Specifications

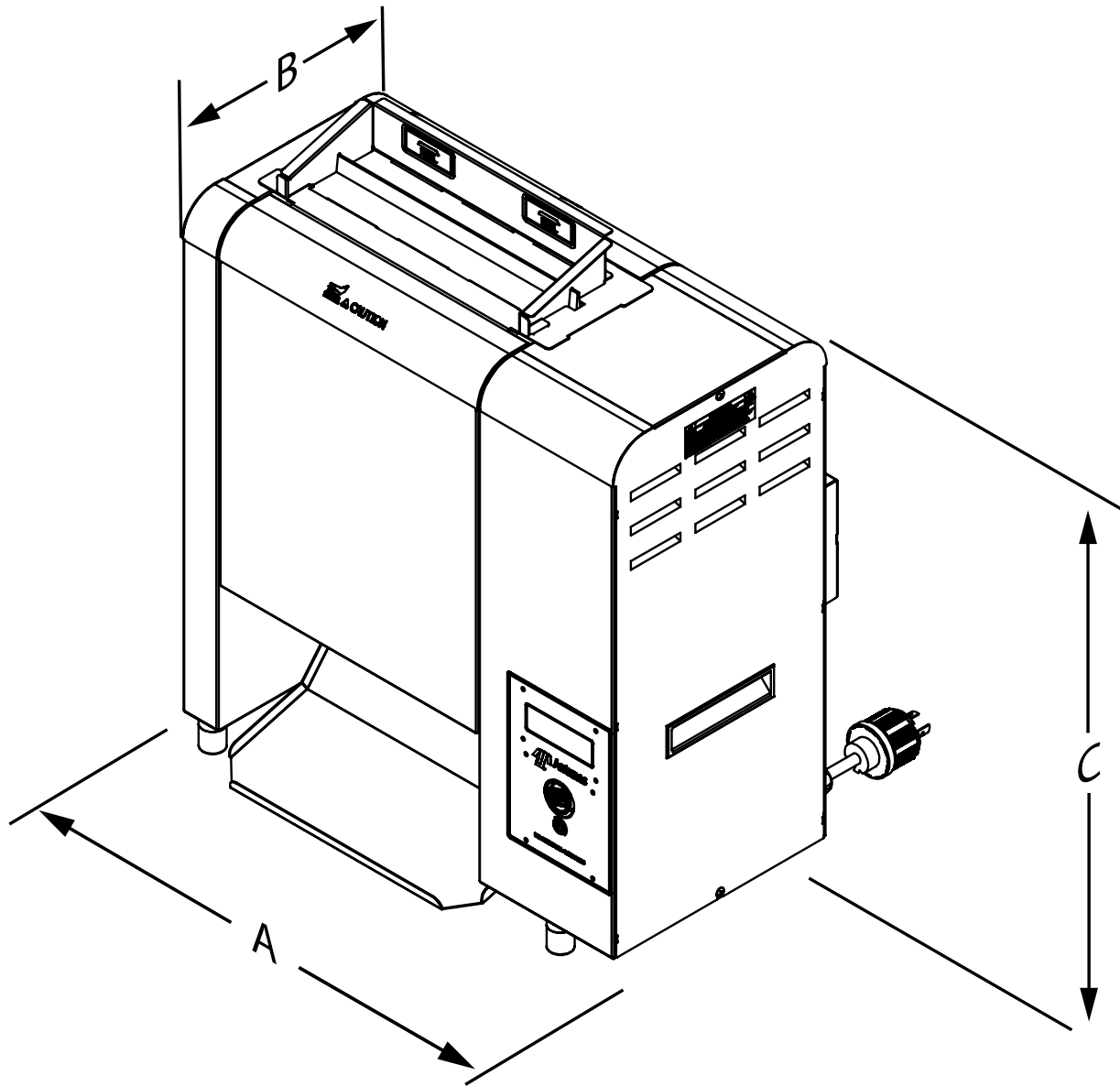

Model & Mfg. No.	Volts	Phase	Hertz	Power	Current
9210131	200-240	1 Phase	50/60	1900W	10

Model #	(A) Width	(B) Depth	(C) Height
9210131	23" (584.2mm)	10 3/4" (273.05mm)	24 3/4" (628.65mm)

Unpacking

1. Remove toaster and all packing materials from the shipping pallet.
2. Remove all shipping tape and protective coverings from the toaster and parts.
3. Open the Accessories Box. It should contain the following:
 - Bun Chute
 - Bun Feeder
 - Two Release Sheets
 - Owner's Manual

NOTICE: If any parts are missing or damaged, contact Antunes IMMEDIATELY at 1-800-253-2991 (toll free in the U.S. and Canada) or at 630-784-1000.

4. Wipe the entire exterior of the toaster and the accessories mentioned above with a hot damp cloth. Allow to air dry completely.

NOTICE: Do NOT use a dripping wet cloth. Wring out before use.

5. Install the Bun Chute, Release Sheet, and Bun Feeder as shown in Figure 1.

NOTICE: Ensure both Conveyor Covers are closed before turning on the toaster. Failure to do so will trigger an **OPEN COVER** Warning. Close the covers to cancel the warning.

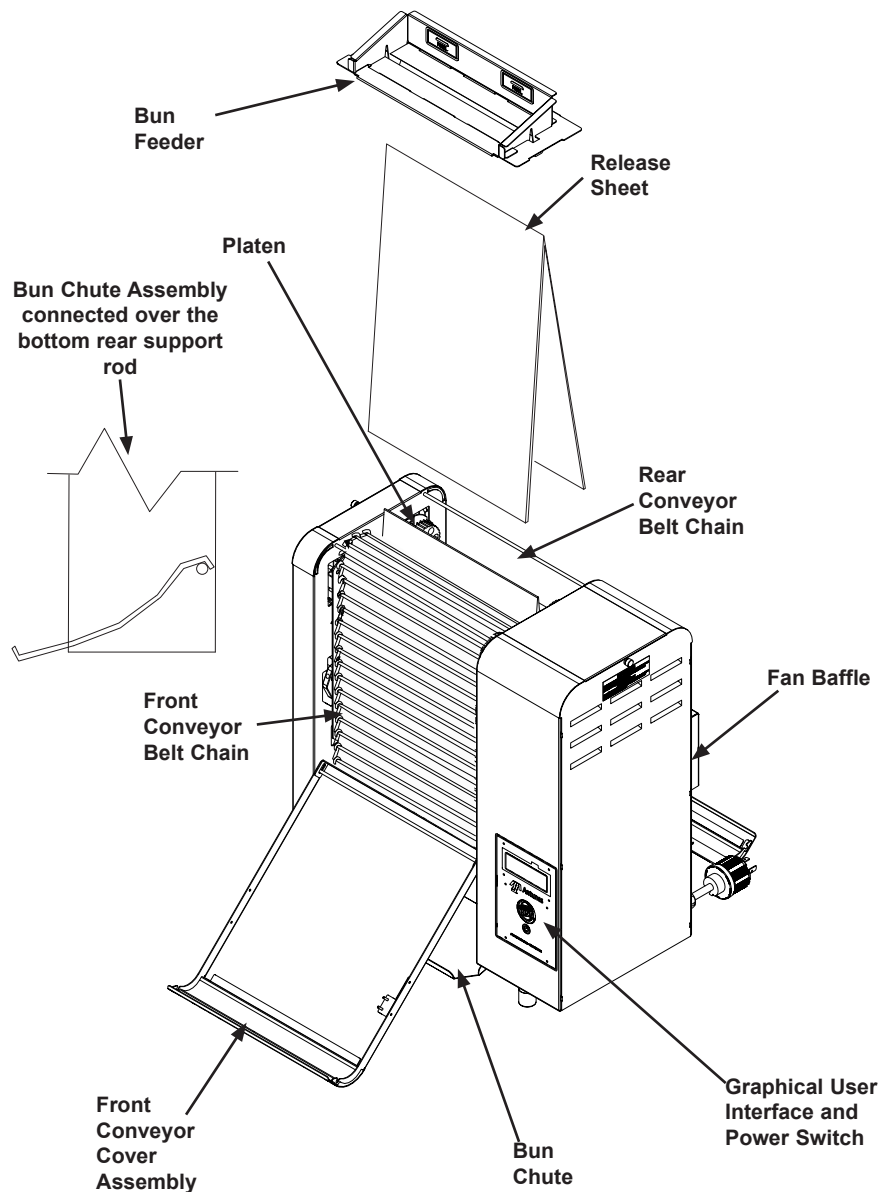

Figure 1. Components

Operating Instructions

Startup

1. Press and hold the Power button for two (2) seconds. The splash screen will appear, followed by the software version screen. The toaster will begin its warm-up. Warm up time is less than 30 minutes.

During the warm-up, the current platen temperature is displayed. When initial Warm-up completes, the toaster displays the Main Menu.

The warm-up screen can be bypassed by touching **FOOD**.

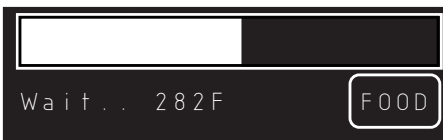

WARNING Toasters are HOT and can cause severe burns. Keep hands and objects out of the toaster. Failure to do so may result in serious injury. Turn the toaster off, unplug it, and check that the toaster is completely cool before touching or servicing.

NOTICE: After 20 seconds of inactivity the toaster will time out. If the toaster is not up to the operating temperature, the display will default to the Warm-Up screen until operating temperature is reached. While at operating temperature, the toaster will default to the Toasting Screen.

System Cooldown

Pressing and holding the power button for two (2) seconds will power off the toaster. It will then go into Cooldown Mode. The unit is off but will continue to show the temperature of the platen during this time. Wait till the toaster is completely cooled and unplug before servicing or moving it.

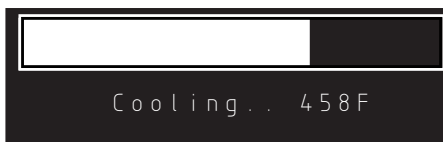

Toasting

To begin start on the main screen:

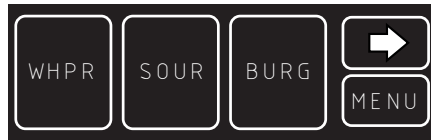

1. Use the arrow key to cycle through the menu items and select an option to open the Toasting Screen.

To choose a different menu item, tap the highlighted menu item button to be returned to the previous screen.



NOTICE: If the initial Warm-Up Screen is bypassed the toaster may not be at operating temperature. In this case, the Toasting Screen may say **WAIT**. If this happens, wait until the Toasting Screen reads **READY** before inserting product.



2. You may change the toasting speed at any time by touching the toast time button to cycle through the three (3) preset values: Light, Medium, & Dark.
3. When the screen reads **READY** you may begin toasting product.
4. Insert product into the toaster with the CUT SIDE facing the PLATEN.

NOTICE: If SOUR is selected, the display will automatically default to WHPR after 20 seconds.

Adjusting Toasting Settings

From the Toasting Screen:



1. Press and hold for one (1) second then release the toast time button.

This opens the timer settings screen for that darkness preset. The current setting is shown in the top right corner in # of seconds.



2. Using the left and right arrow keys, adjust the time to the setting desired.
3. Touch **OK** to save the adjusted setting and return to the Toasting Screen.

Adjusting Bun Compression

This toaster features compression knobs that are adjustable for different bun thickness.

Increase the compression setting for buns that are taller in height and decrease for buns that are shorter.

NOTICE: For darker toast decrease the compression setting. For lighter toast increase the compression setting.

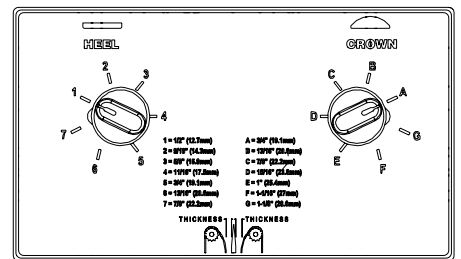

Figure 2. Bun Thickness Compression Control

Crown - Rotate knob Counterclockwise to increase and clockwise to decrease the compression setting

Heel - Rotate the knob clockwise to increase the and counterclockwise to decrease the compression setting.

Manager Menu

Touching MENU from the main menu will open up the Manager Menu. You can access the options for Status, Errors, Programming, and Resetting.

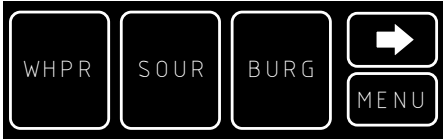

Touch MENU to return to the main screen to exit.

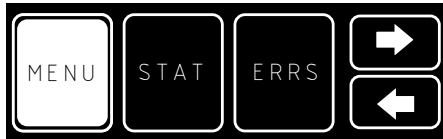

Use the arrow keys to show the different Manager menu options.

Status Menu:

Touch **STAT** from the Manager Menu to open the Status Menu.



Use the up and down arrow buttons to view the statuses for:

- Platen Temperature
- Power
- Board Temperature
- Motor Speed
- Total Run Time (Total time the toaster has been ON)

Touch **STAT** again to be returned to the Manager Menu.

Error Log:

Touch **ERRS** from the Manager Menu to open the Error Log.

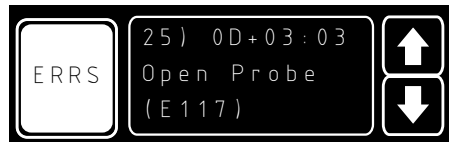

Errors are listed in reverse order with the most recent error listed first. Up to 30 errors can be stored in the system. Use the up and down arrow buttons to view the logged errors.

Error time is displayed as time elapsed since the error occurred. If the error occurred less than 100 days before, then it will be displayed in the following format:

Days, Hours: Minutes.

The above example shows that the error occurred 0 Days, 3 hours and 3 minutes ago.

After 100 days, the error will be displayed in number of days only.

Touch **ERRS** again to be returned to the Manager Menu.

Program Menu:

Touch **PRGM** from the Manager Menu to open the Program Menu.

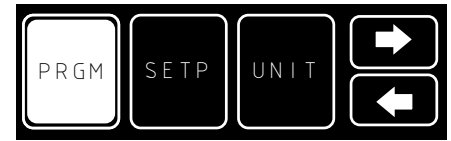

There are several options to adjust in the Program Menu: Set Platen Point, Units, Beeper Volume.

Selecting **SETP** will open the **Platen Set Point Temperature Menu:**

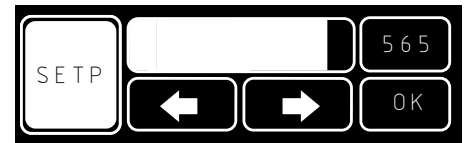

The default set-point temperature is 565F.

Adjust the Set Point Temperature using the arrow keys. Touch **OK** to save your changes or **SETP** to return to the Program Menu without saving.

The temperature is shown in Fahrenheit by default. To change units, select **UNIT** to change the display unit (Fahrenheit or Celsius)

Select **VOL** to change the beeper volume (Off, Low or High)

Reset Menu:

Touch **RSET** from the Manager Menu to open the Reset Menu.

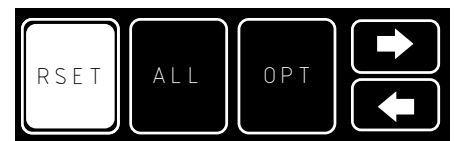

There are several options for resetting: All, Options (All Options in the Program Menu), Food (All darkness for food items), and Errors (to clear the Error Log).

Use the arrow keys to navigate. Touch the desired menu item to reset it.

Touch **RSET** again to be returned to the Manager Menu.

Daily Maintenance

The toaster requires a minimal amount of maintenance. Daily maintenance helps keep the toaster running smoothly and free of any excess buildup that comes from daily use and wear. These steps should be completed at the end of every day to ensure that the toaster maintains optimum efficiency.

⚠WARNING The toaster will remain hot to the touch while it is cooling down. Personal injury and burns may result from touching the toaster before it is finished cooling down. Wear Heat Resistant Gloves during all cleaning processes.

Cleaning the Accessories and the Toaster

1. Push the Power Button to turn the toaster off.
2. The toaster will enter the cool down mode. The fan will continue to run. This cool down mode will shut the toaster down automatically when complete.
3. Wearing Heat Resistant Gloves, remove the following items from the toaster (refer to Figure 1):
 - Bun Feeder
 - Bun Chute
 - Release Sheet
4. Wash the Bun Feeder and Bun Chute in a three compartment sink. Let air dry.

NOTICE: Do NOT wash any of the accessories in a Power Soak Machine or any other mechanical washer. Damage to the accessories may result. Wash all accessories by hand in the sink

5. Wipe down the outside of the toaster with a clean, sanitized towel dampened with non-corrosive cleaning solution.

Cleaning the Release Sheet

1. Remove the Bun Feeder and Release Sheet and inspect both sides of the Release sheet.

NOTICE: Replace the Release Sheet if it is overly worn, creased, or torn.

2. Lay the release sheet on a clean, flat, dry surface. Spray a multipurpose cleaner on a clean, dry towel.
3. Wipe the Release Sheet firmly from top to bottom over its entire surface.
4. Immediately repeat this procedure with a clean, dry towel dampened with water.
5. Wipe the entire Release Sheet with a clean towel dampened with sanitizer solution and allow to air dry.
6. Turn the Release Sheet over and repeat Steps 2 through 5 on the reverse side.
7. Allow Release Sheet to completely dry before installing.
8. Reinstall the Release Sheet, checking to make sure it is draped properly over the Platen.

NOTICE: Rotate the reversible Release Sheet from side to side daily to extend the life of the Release Sheet.

Cleaning the Conveyor Belts

Wear heat resistant gloves during the belt cleaning process to avoid risk of burns or cuts while cleaning.

NOTICE: Grill Cleaner is most effective when used while the toaster is still warm. Do NOT wait for the toaster to cool down completely before cleaning.

1. Face the front of the toaster. From the bottom of the Conveyor Cover Weldment, lift up and tilt the cover away from the toaster to expose the Conveyor Belt.

NOTICE: The conveyor belts will rotate slowly during “Cooling Mode” unless the covers are open.

2. Spread a light coating of high temperature grill cleaner or degreaser on a non-scratch pad or clean towel.
3. Applying moderate pressure, scrub the metal slats side to side until clean.

NOTICE: There is a metal backing plate behind the conveyor to provide support for cleaning the slats. Only clean the conveyor while it is against the backing plate in the center to prevent damage to the unit.

4. Wipe the conveyor belt with another clean, towel sprayed with sanitizer solution. Let the belt air dry.
5. Close the front Conveyor Cover, making sure it locks into place.
6. Repeat steps 1-5 to clean the rear conveyor belt.

Quarterly Maintenance

Clean Cooling Fan

To ensure proper airflow and help prevent the occurrence of fan fault or error messages the cooling fan intake vent and/or fan should be periodically cleaned.

1. Turn the toaster off and allow the toaster to complete its cool down.
2. Unplug the power cord.
3. Locate the Fan Baffle on the rear of the toaster. Pull the pin out and tilt the baffle up and away from the toaster to remove. (See Figure 3)

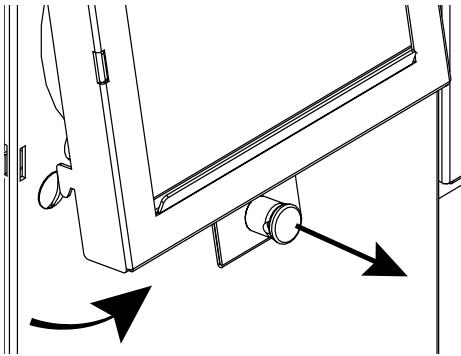

Figure 3. Fan Baffle Removal

4. Wipe away any debris and lint from the fan baffle and air intake vent with a clean towel.
5. Reinstall Fan Baffle to toaster and plug in power cord.
6. Return toaster to use.

NOTICE: It is very important to keep the cooling fan and electrical compartment clean and in top operational mode. Do not ignore these cleaning steps.

Checking Conveyor Chains

This unit features an take-up system that automatically applies tension to the conveyor chain as it wears/ stretches. Over a period of time however, the take-up system can reach it's maximum level resulting in the conveyor chain eventually skipping on the sprockets. This is easily remedied by removing one or more conveyor links from each side of the belt.

1. Turn the toaster off and let it enter cooldown mode.
2. Open both conveyor covers. The belts will be rotating slowly during cooldown mode.
3. Locate the bottom Idler shaft on the front and rear conveyors. If the belt is skipping a link(s) will need to be removed.
4. Close the conveyor covers and let the unit cool before proceeding. Unplug the power cord.
5. Remove the Bun Feeder
6. Remove the release sheet to avoid damaging it during the belt link replacement process.
7. Open both Conveyor Covers.
8. Disconnect the Conveyor Belt Chain by squeezing any two links together and unhooking both ends of one link (Figure 4). Needle-nose pliers may be used

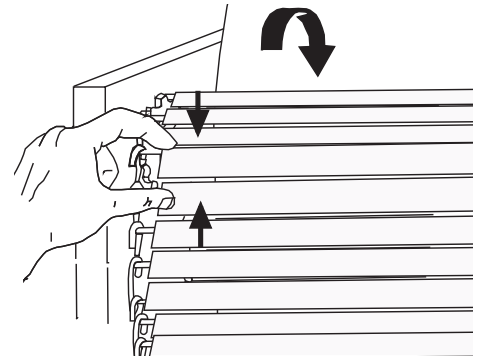

Figure 4. Remove Belt Link

9. To shorten a stretched Conveyor Belt Chain, remove one complete link from the chain.

NOTICE: The ends of the hooks must point down (Figure 4).

10. Wrap the Conveyor Belt Chain around the top and lower sprockets and connect by hooking both ends together.

NOTICE: Some pressure may need to be applied to the top idler shaft by pressing it down to provide more slack to the belt when reinstalling the conveyor belt chain.

Error Messages

If the toaster displays any error messages, touch the error button to silence the error beeper.

Touch the error button turn the toaster off and restart it. If the error persists, contact Antunes Technical Service: 1-877-392-7854 (toll free).

Error Code	Error	Description	Corrective Action
E101	HI-LIMIT	High-Limit is triggered.	Allow sufficient time (10-15 minutes) for the unit to cool down. Remove the Hi-Limit control cap at the rear of the unit. Press the Hi-Limit Reset button. Turn the unit on and test the unit by toasting some product. If the Hi-Limit continues to trip, contact Antunes Technical Service at +1-877-392-7854 for assistance.
E117	OPEN PROBE	Thermocouple connection is open.	Re-secure the Platen Thermocouple connection to the Control Board. If the Control Display still reads "Open Probe" If message persists, contact Antunes Technical Support at +1-877-392-7854 (toll free) for assistance.
E135	WARMUP TIME	The unit is taking too long to warm-up.	Cycle Power OFF Unplug unit for 30 seconds Cycle Power ON . If message persists, contact Antunes Technical Support at +1-877-392-7854 (toll free) for assistance.
E10	MOTOR COMM	Unit cannot communicate with motor.	
E2	ZERO CROSS	Internal control board error.	
E6	MEMORY	Memory chip error.	
E105	OVERTEMP	Temperature is 25°F over Set Point Temperature.	
E111	UNDERTEMP	Unit drops 100°F below Set Point Temperature when in READY state.	
E305	MOTOR SLOW	Motor speed drops below 75%.	Check the conveyor belts & surrounding areas for any obstructions/jams. Contact Antunes Technical Support at +1-877-392-7854 (toll free) for further assistance.
E300	MOTOR STOP	Motor Failure.	Inspect the cooling fan on the back for operation and ensure it is clean. If needed, clean the cooling fan or replace.
E123	BOARD TEMP	Control Board is too hot.	
	Warning	Description	
OPEN COVER		Conveyor cover isn't locked in place. Check conveyor covers.	Inspect both conveyor covers and ensure that they are properly engaged.
MOTOR LOAD		Motor speed drops below 90% for 5 seconds.	Check the conveyor belts & surrounding areas for any obstructions/jams. Contact Antunes Technical Support at +1-877-392-7854 (toll free) for further assistance.

CAUTION

Use of any replacement part other than those supplied by Antunes or their authorized distributors can cause injury to the operator and damage to the equipment and will void all warranties.

WARNING

Before replacing any parts, or opening any side or rear panel from the toaster, disconnect the toaster from the electrical power supply.

Replacement Parts

Parts list (see Exploded diagrams below)

Note
Use only genuine Antunes replacement parts in this unit. Use of parts other than those supplied by the manufacturer will void the warranty.

Item No.	Part #	Description	QTY.
1a	7001966	Conveyor Belt, Formed	2
1b	7001967	Conveyor Links Kit	
2	70P0249	Release Sheet (3 Pack)	1
3	7001991	Bun Feeder	1
4	7001984	Platen, Grill 200V/1900W	1
5	7001985	Rear Conveyor Cover	1
6	7001986	Front Conveyor Cover	1
7	7001988	Compression Label	1
8	7001989	Side Housing Panel kit	1
9	7001990	Control Side Panel Kit	1
10	7001965	Control Label	1
11	7001993	Bun Chute	1
12	7001611	Handle Snap-In	2
13	7001000	Rubber Leg Kit	4
14	7001957	Main Board Kit	1
15	7001958	Display Board Kit	1
16	7001959	Motor Board	1
17	7001960	Capacitor	1
18	7001961	Display Cover	1
19	7001962	USB Cable	1
20	7001963	MOV Board	1
21	7001968	Fan Baffle	1
22	7000913	Fan 230VAC Kit	1
23	7001969	Drive Chain	1
24	7001970	Drive Shaft	2
25	7001971	Idler Shaft	2
26	7001972	Spring Guide LH/RH	4
27	7001973	Plate Tensioner	4
28	7001974	Spring Bearing Retainer	4
29	7001975	Cam Compression R/L	4
30	7001976	Cam Shaft	2
31	7001977	Motor Sprocket	2
32	7001978	Drive Sprocket	8
33	7001979	Dive Bearing Retainer	2
34	7001980	Idler Bearing Retainer	2
35	7001981	Idler Sprocket Assy	8

Item No.	Part #	Description	QTY.
36	7001982	Support rod	2
37	7001983	Support Cover	2
38	7001987	Spring Compression	8
39	7001964	Door Sensor Board	2
40	0700437	Power Cord - IEC 309	1
41	7001144	Thermostat, Hi-Limit 700F	1
42	7001609	Terminal Block, S-Series	1
43	7001143	Solid State Relay	1
44	7001527	Cap-Mp Motor Run	1
45	7000500	Motor	1
46	7001033	Bearing Assy	2
47	7001324	Knob	2
48	7001293	Thermocouple, Type K	1
49	0013862	Conveyor Frame, Front	1
50	0013863	Conveyor Frame, Rear	1
51	0509113	Bracket, Motor Board Mount	1
52	0509148	Bracket, Conveyor Frame Mount	4
53	0509365	Bracket, Motor Mounting	1
54	0510017	Bracket, Tensioner	1
55	0600158	Spring, Roller Tension	4
56	1000900	Label - Warning	1
57	1001180	Label - Heel	2
58	1001213	Label - Shock Hazard	1
59	1002774	Label - Wiring Diagram	1
60	3250219	SH Bolt 5/16 Dia X 1" LG 1/4-20	8
61	304P105*	Nut, Hex "KEPS" #4-40 Zinc	-
62	306P130*	Nut, Hex "KEPS" #06- 32 Steel; Zinc Plated	-
63	308P143*	Nut, Hex "KEPS" #8-32	-
64	310P102*	Washer, Int. Tooth- Lock, #10	-
65	310P134*	Nut, #10-32 Acorn	-
66	310P146*	Nut, Hex "KEPS" #10- 32	-
67	310P178*	Screw, Hex Bolt #10-32 X 3/8"	-
68	4070345	Filter Board, 16 Amps	1

* Indicates that item can only be purchased in packs of ten (10).

Exploded Diagram 1

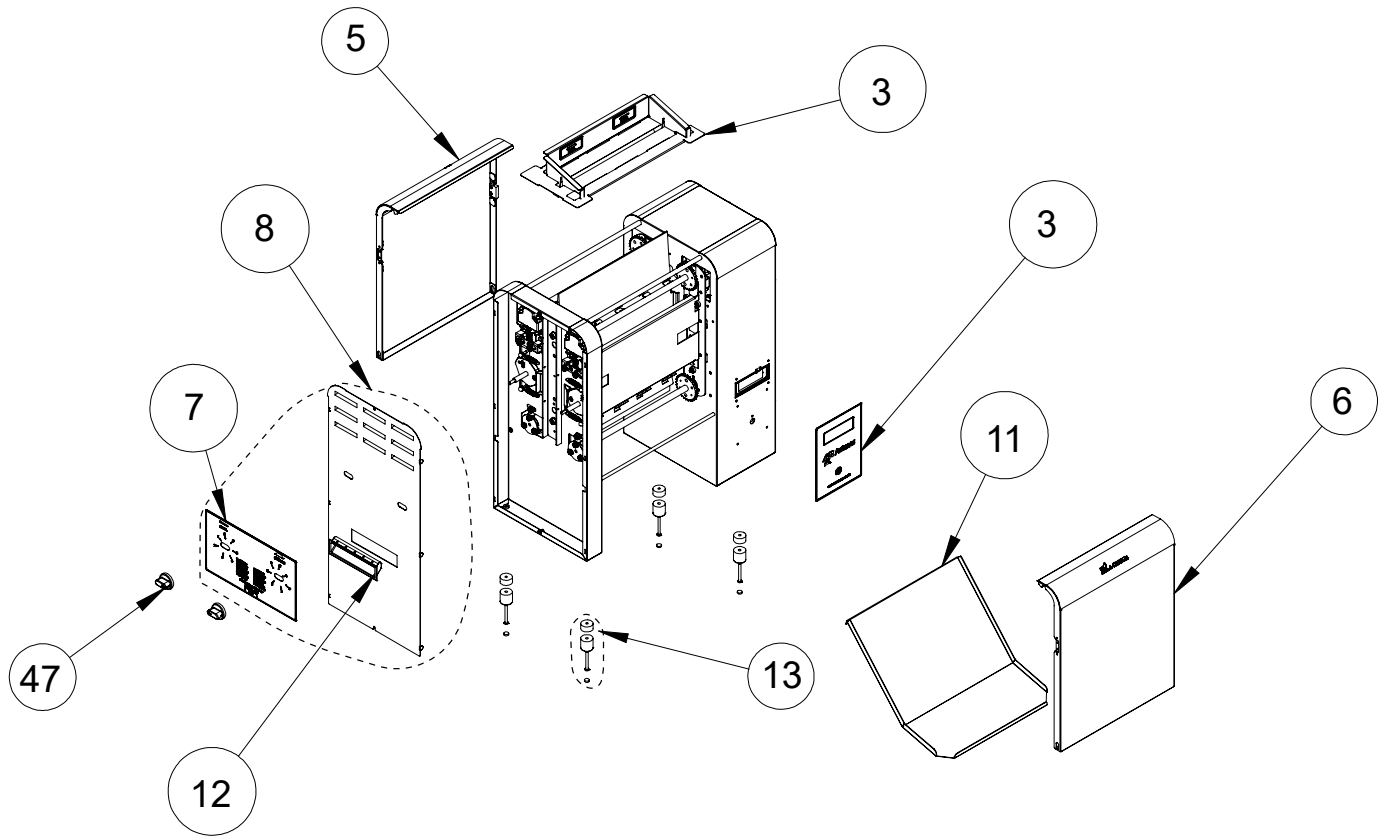

Exploded Diagram 3

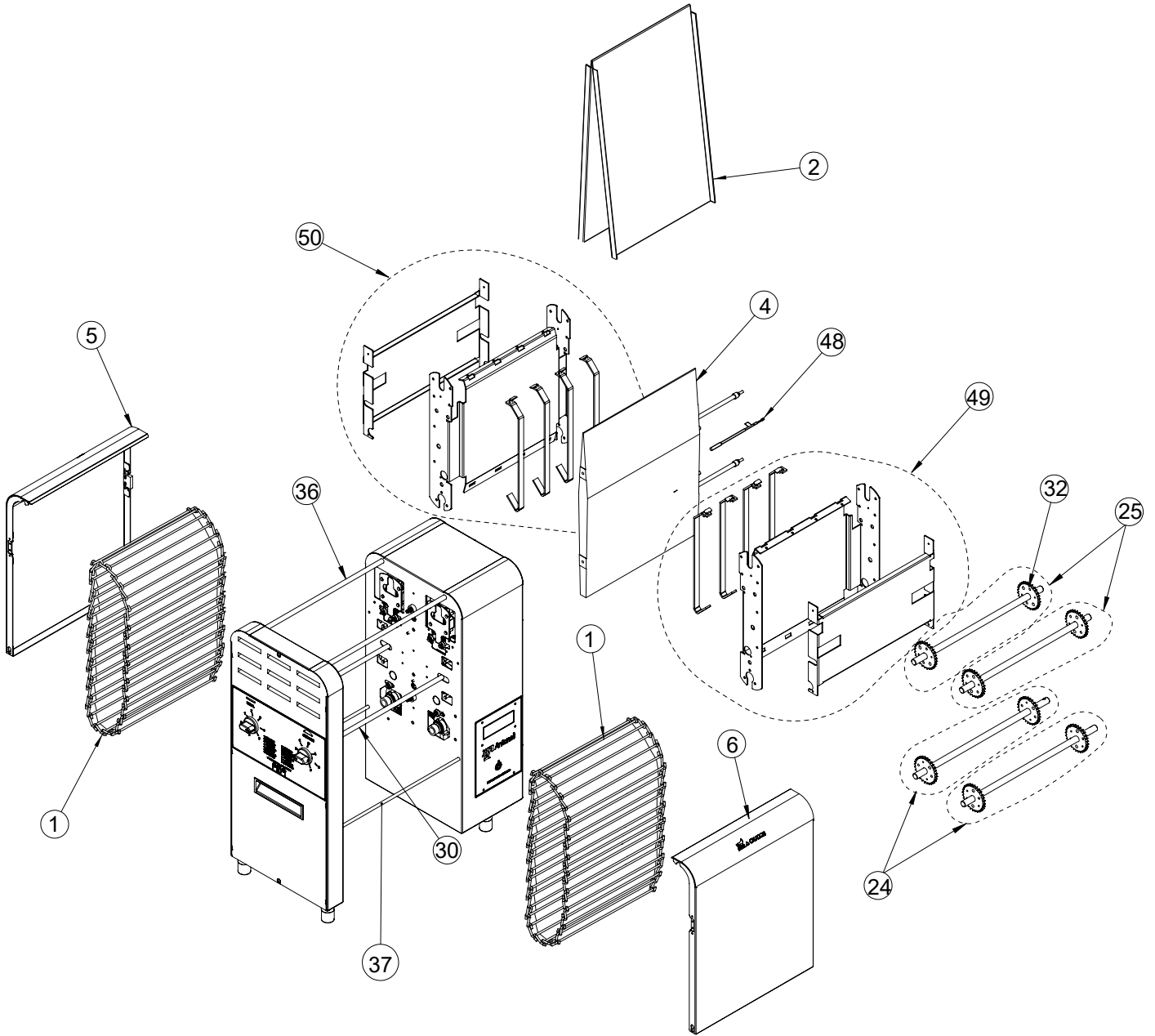

Exploded Diagram 4

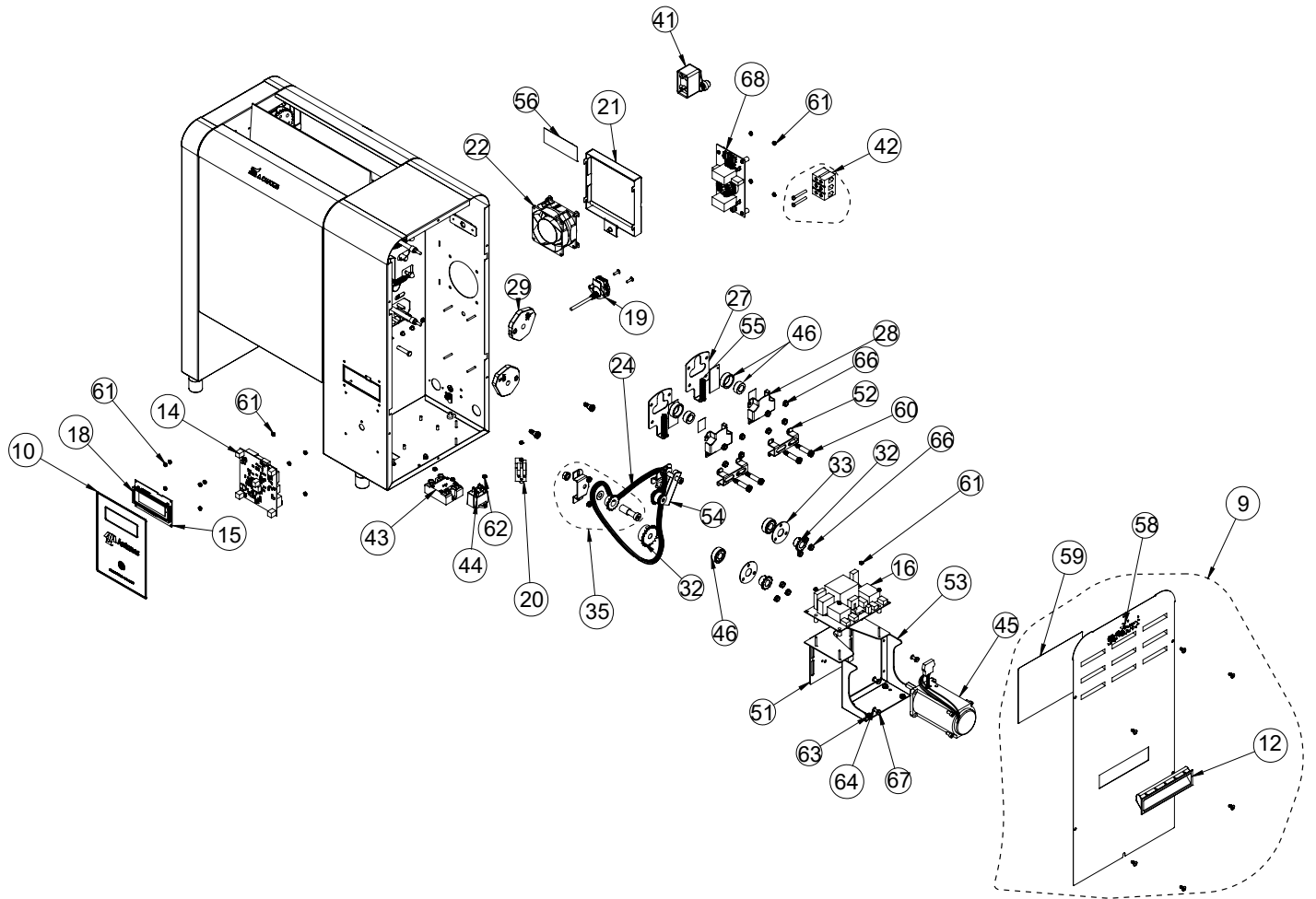

Wiring Diagram

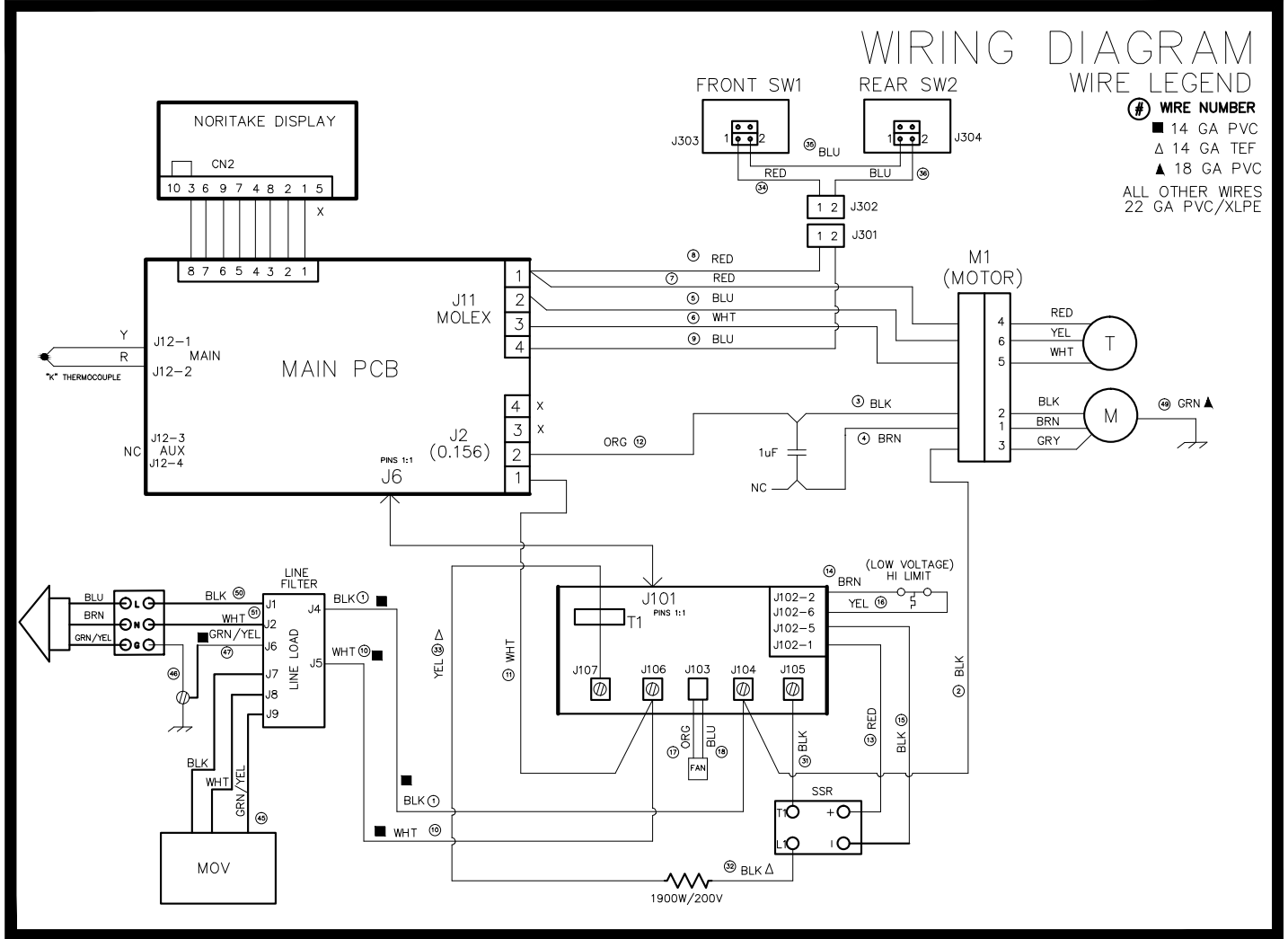

Limited Warranty

Equipment manufactured by Antunes has been constructed of the finest materials available and manufactured to high quality standards. These units are warranted to be free from electrical and mechanical defects for a period of one (1) year from date of purchase under normal use and service, and when installed in accordance with manufacturer's recommendations. To insure continued operation of the units, follow the maintenance procedures outlined in the Owner's Manual. During the first 12 months, electromechanical parts, non-overtime labor, and travel expenses up to 2 hours (100 miles/160 km), round trip from the nearest Authorized Service Center are covered.

This warranty does not cover cost of installation, defects caused by improper storage or handling prior to placing of the Equipment. This warranty does not cover overtime charges or work done by unauthorized service agencies or personnel. This warranty does not cover normal maintenance, calibration, or regular adjustments as specified in operating and maintenance instructions of this manual, and/or labor involved in moving adjacent objects to gain access to the equipment. This warranty does not cover consumable/wear items. This warranty does not cover damage to the Load Cell or Load Cell Assembly due to abuse, misuse, dropping of unit/shock loads or exceeding maximum weight capacity (4 lbs). This warranty does not cover water contamination problems such as foreign material in water lines or inside solenoid valves. It does not cover water pressure problems or failures resulting from improper/incorrect voltage supply. This warranty does not cover Travel Time & Mileage in excess of 2 hours (100 miles/160 km) round trip from the nearest authorized service agency.

Antunes reserves the right to make changes in design or add any improvements on any product. The right is always reserved to modify equipment because of factors beyond our control and government regulations. Changes to update equipment do not constitute a warranty charge.

If shipment is damaged in transit, the purchaser should make a claim directly upon the carrier. Careful inspection should be made of the shipment as soon as it arrives and visible damage should be noted upon the carrier's receipt. Damage should be reported to the carrier. This damage is not covered under this warranty.

Warranty charges do not include freight or foreign, excise, municipal or other sales or use taxes. All such freight and taxes are the responsibility of the purchaser.

This warranty is exclusive and is in lieu of all other warranties, expressed or implied, including any implied warranty or merchantability or fitness for a particular purpose, each of which is hereby expressly disclaimed. The remedies described above are exclusive and in no event shall Antunes be liable for special consequential or incidental damages for the breach or delay in performance of this warranty.

The warranty does not extend to:

- Damages caused in shipment or damage as result of improper use.
- Installation of electrical service.
- Installation, calibration, or adjustment.
- Normal maintenance outlined in this manual.
- Malfunction resulting from improper service or maintenance.
- Damage caused by improper installation, abuse, or careless handling.
- Damage from moisture getting into electrical components.
- Damage from tampering with, removal of, or changing any preset control or safety device.
- Damage caused by parts or components not provided by Antunes



Corporate Headquarters

Carol Stream, Illinois
Phone: +1 (630) 784-1000
Toll Free: +1 (800) 253-2991
Fax: +1 (630) 784-1650

China Facility

Suzhou, China
Phone: +86-512-6841-3637
Fax: +86-512-6841-3907